

Kunststofftechnik Jantsch GmbH

JANTSCH

We put your ideas into best shape.

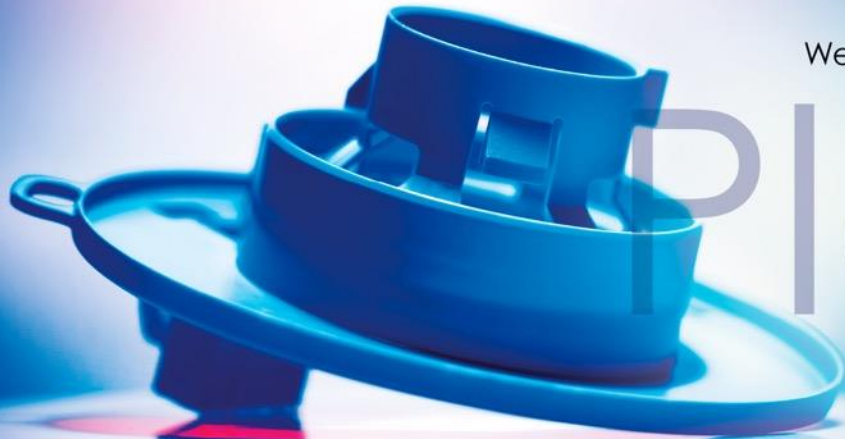

Plastics Technology

- Product development
- Mold making
- Precision plastic parts

Our company building in Nürnberg

here.



Our facts and figures

unique.



- Approx. 85 employees (state 2023)
- 13 Mio. EUR turnover (state 2023) in our three divisions:
- Long-time growth approximately 10 % per year
- ERP system **TimeLine**
MES/BDE system **ProSeS**

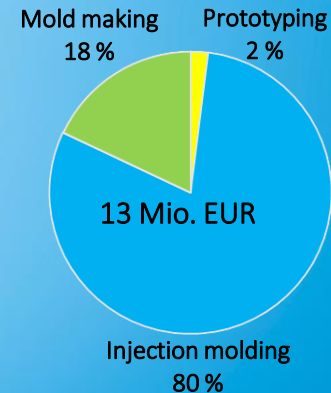

Our history

dynamic.



The managing directors (from left)
Dipl.-Ing. Stephan Loh,
Florence Lefellier-Loh and
Dipl.-Wirtsch.-Ing. Wieland P. Loh

- 1952 Foundation as an engineering office by Ing. Franz Jantsch in Nuremberg
- 1964 Expansion by an own mold making department
- 1980 Takeover by Mr. Dipl.-Wirtsch.-Ing. Wieland P. Loh
- 1985 Relocation to Stein
- 1993 Change of the company name to Kunststofftechnik Jantsch GmbH
- 2002 Takeover of the company Siscoform
- 2005 Relocation to the current site in Nuremberg
- 2022 Handover of the management to Dipl.-Ing. Stephan Loh

Distribution of turnover by industries

diversified.



Our product portfolio



Our product development

designing

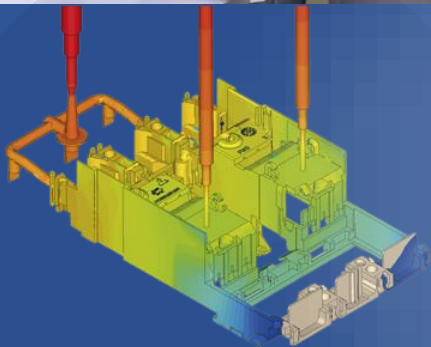

Simulation of mold filling with valve gate hot runner and cascade system

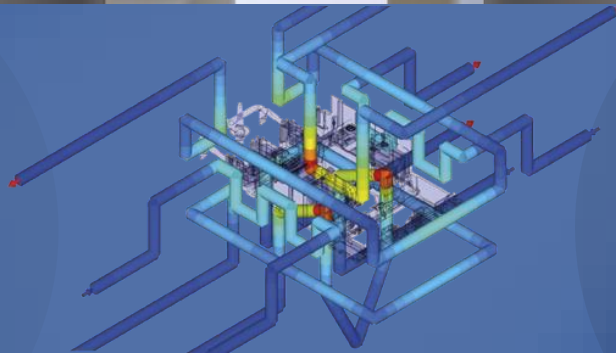

Consideration of the cooling channels to identify hotspots and to recreate the serial process realistically

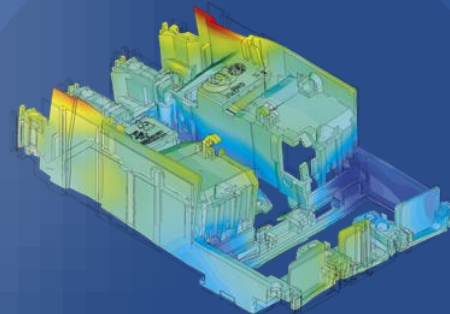

Realistic prediction of part warpage:
Calculation of the pre-correction geometry

Our prototyping

innovative.



Raise3D
Pro3 Plus

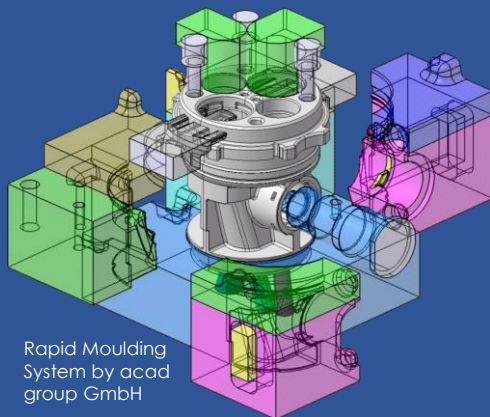

Rapid Moulding
System by acad
group GmbH

- In house:
3D printing, vacuum casting,
preliminary series molds out of unhardened steel
- With partners:
Diverse additive technologies like laser sintering,
preliminary series molds out of milled aluminum

Our mold making department

perfectly formed.



8-cavity injection mold with hot runner,
4 sliders, cycle time less than 7 seconds



2-cavity injection mold with hot runner,
2 sliders, 2 core pullers and overmolded
metal inserts



2-cavity injection mold with needle valve hot
runner (cascade filling technology) and 4 sliders

- o Temperature-controlled workshop for highest precision
- o Capacity planning and progress monitoring with **PLANTOOL**
- o Part and mold design using **SOLIDWORKS**
- o Programming using **MASTERCAM**
- o High degree of work flow automation by **CERTA** job-management-system
- o Robot infeed and removal with **EROWA** robot System

Our mold making department

perfectly formed.



Our precision

precise.

Knowledge and automation.

Our many years of experience as well as professional control of modern manufacturing methods and automated processes allow us to build high-performance molds with the highest precision.

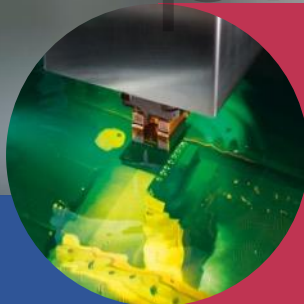

Sinker EDM with graphite electrodes for highest precision

Fully automated change of sinking electrodes and workpieces by robot system



High speed milling of the hardened inserts with up to 42,000 rpm



High number of variants due to interchangeable inserts and cores

Our injection molding department

productive.

GmbH
antsch.de
E-1-A
Artikelnr.: Y 307
Artikelnr.:
Immer B23-30379
28 / 2019 / 350kg



2-component production
with turntable technology

- 29 modern injection molding machines with clamping forces from 180 kN to 2,200 kN are all equipped with removal devices like multi-axis robots
- Three 2-component machines: hard/soft and two-color
- Automated feeding and overmolding of inserts
- Automated optical part inspection (camera and laser systems)
- Clean room production of optical parts

Our quality

qualitative.

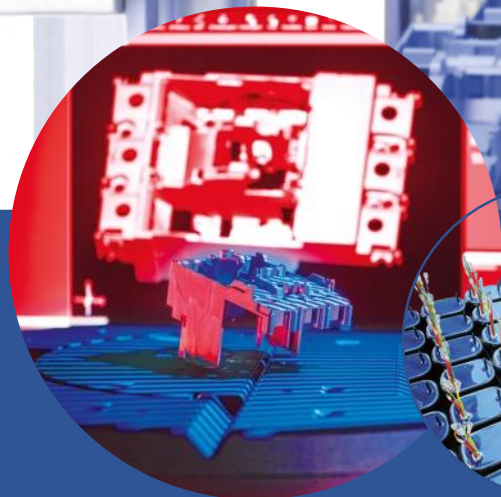

Complete measurement of the component surface by 3D scan: Generation of data for mold correction using a target-actual comparison

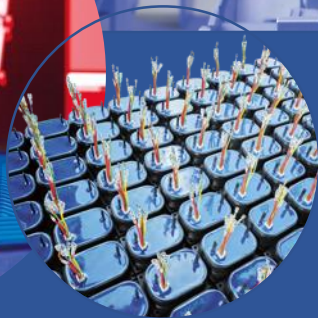

Vacuum casting of electronic circuits with epoxy compound in an ESD-validated environment

- Zero-defect strategy (e.g. internal 8D reports)
- CAQ system: **QUIPSY**
- 3D coordinate measuring machine: **Carl Zeiss Contura G2 700**
- CNC video measuring microscope: **Garant MM1-300**
- 3D scanner: **Keyence VL-500**
- Residual moisture metering: **Aboni FMX HydroTracer**
- Certified according: **DIN EN ISO 9001, 14001 und 50001**



Quality control during production, supported by modern CAQ software



Our strengths

strong.

- Complete process chain by one partner (design to series production)
- Products of high quality at current state of technology
- Technical and economic consulting
- On time delivery
- Modern plant and machine equipment
- Highly motivated and qualified employees

Our contact persons

Management



Dipl.-Ing.
Stephan Loh, MBA
CEO



Florence Letellier-Loh
CEO



Dipl.-Wirtsch.-Ing.
Wieland P. Loh, M.Sc.
Advisory Board



Sebastian Thomann, M.Sc.
Head of Sales,
authorized signatory

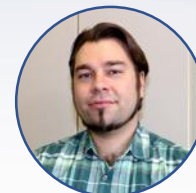

Michael Reuter
Sales

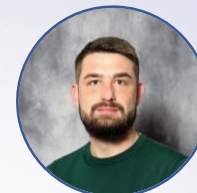

Florian Kleeberg
Sales

Mold making



Jörg Huber
Head of Mold making



Martin Gronauer
Head of Design



Thomas Wirth
Operations Manager



Bassam Hamasaeed
Head of Production

Quality management



Thomas Fischer
Head of Quality management



Dipl.-Ing. Helena Heier
Quality management

We put your ideas into best shape.

A stack of white plastic dishes including a plate, a bowl, and a cup, with a small container on top, all resting on a stand. The image is semi-transparent and serves as a background for the text.

Thank you for your interest in us
and we are looking forward to our cooperation.

Your entire Jantsch team.

www.jantsch.de